

# SICK BUILDING SYNDROME: IMPACT OF IDEAL ROOFING ON OCCUPANTS HEALTH

Ifeanyi Chukwudi Obi  

<sup>1</sup>ObiSoft Innovations UK, England, United Kingdom

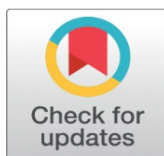

**Received** 26 February 2024

**Accepted** 28 March 2024

**Published** 11 April 2024

## Corresponding Author

Ifeanyi Chukwudi Obi,  
[Dranyiobi@gmail.com](mailto:Dranyiobi@gmail.com)

## DOI

[10.29121/granthaalayah.v12.i3.2024.5581](https://doi.org/10.29121/granthaalayah.v12.i3.2024.5581)

**Funding:** This research received no specific grant from any funding agency in the public, commercial, or not-for-profit sectors.

**Copyright:** © 2024 The Author(s). This work is licensed under a [Creative Commons Attribution 4.0 International License](https://creativecommons.org/licenses/by/4.0/).

With the license CC-BY, authors retain the copyright, allowing anyone to download, reuse, re-print, modify, distribute, and/or copy their contribution. The work must be properly attributed to its author.



## ABSTRACT

Sick Building Syndrome (SBS) has been defined as a “set of adverse health or discomfort symptoms that individuals experience when they spend time indoors, particularly in office buildings, and that lessen while away from the building” [Apte et al. \(2000\)](#). Various construction elements such as windows, floors, roof designs and construction methods can substantially increase or reduce health and safety levels. This can affect internal and external environments in workplaces. Therefore, the more sustainable the construction elements, the less hazardous or negative impacts on the building construction, the workforce, the environment, the occupants and vice versa. This study aims to use existing building construction elements and designs in North Cyprus to create a framework for developing and evaluating suitable roofing structures for adequate insulation in the North Cyprus residential buildings. This was achieved through research experiments on the construction of building elements, that is, roofing. Most SBS buildings in Cyprus have no roof structure or adequate insulation. Therefore, this experiment was carried out to prove that wrong roof systems contribute to SBS formation in buildings and the rate of SBS effects on the end users.

**Keywords:** Sick Building Syndrome, Building, SBS, Roofing

## 1. INTRODUCTION

Generally, roof types have a considerable impact on heat control both within and outside the building. Insufficient or non-existent roof insulation, an inadequate roofing system, or low-quality materials used in roof design and construction are common causes of temperature instability in rooms [Wargocki et al. \(2000\)](#). These factors can facilitate SBS formation in a building and enhance the SBS effect on end users. Symptoms like dry cough, dry and itchy skin, nose bleeding, heart palpitations, exhaustion after a little activity, joint pain, swelling of the legs, ankles and trunk, pregnancy challenges like miscarriages and even drowsiness are known to be causes of “sick building syndrome” [Norbäck \(2009\)](#). More roof insulation will improve heat retention in residential structures, lowering the SBS effect on end

users throughout the winter [Skov et al. \(1989\)](#). When additional insulation is added to the roof, heat loss through the building's roof is reduced, if not eliminated, thus preventing the formation of SBS. This is a technique for reducing the prevalence of SBS in residential buildings [Seppänen & Fisk \(2002\)](#). Another option is to reinstall and seal the roofing shingles to keep the heat inside the building. A timber finish may also be used on the ceiling to retain the thermal energy inside the structure. This method is commonly used due to its reduced cost.

## 2. METHODOLOGY

This study was accomplished by comparing data collected from end users' responses to how they react to SBS issues in two apartments in the same building. These apartments have identical characteristics, one with a roof strengthened with suitable insulating materials and one without. A higher response rate to SBS will disclose which flat is best positioned to reduce the SBS effect on occupants. Having considered the weather conditions in Cyprus to determine the best roof design that could best fit the new buildings and what can be done to remedy the existing buildings; additionally, this work will compare the results obtained with various roof insulation systems to determine the most suitable roof design that can limit SBS formation on buildings. This experiment will determine how wrong roofing systems encourage SBS formation in buildings due to inadequate heat control. It will also measure the insulation levels for different roof and ceiling designs thereby creating options that can be applied in a roof or ceiling installation.

### The buildings

Figure 1



Figure 1 Shows Flat D and Flat E Respectively.

Flats D and E share similar designs with the same floor finishes. Both of the buildings are in Lefke, North Cyprus, and their occupants are students who have been there for a minimum of 2.5 years. The obvious distinction is that one has a double-layered insulation-reinforced roof, while the other does not. The goal of this study is to demonstrate how variations in roof insulation affected the SBS effect on building occupants in both buildings. Both buildings already show physical signs of different stages of SBS formation.

In this case study, an investigation was carried out on two similar flats labelled D and E. The occupants were interviewed and also given questionnaires to examine how they responded to the buildings. The occupants of these residential flat

buildings formed the study population and Seven (7) sample sizes were chosen by the Taro Yamane’s Model. The seven (7) respondents were selected using the simple random sampling system or technique (three and four from each flat). The Questionnaire contains three sections and seven respondents living in the two buildings received the questionnaire. The three sections are:

- The health issues noticed while occupying the building
- Assessment of the occupants' activities in the building
- Occupants' level of control over their living conditions.

The data was received from 100% of the respondents making Seven (7) respondents. For flat D, four (4) out of four respondents returned their questionnaire. For flat E, three (3) out of three respondents returned their questionnaires. All the data obtained through the field study was presented in tables. This is to ensure that the research findings are accurately comprehended and assessed. The questions and various responses were analysed and presented.

This study presents critical procedures for evaluating how optimal roof insulation can reduce the SBS effect on occupants in residential structures. Several studies and experiments have led to the conclusion that inadequate or non-existent roof insulation leads to more severe cases of SBS effect on occupants. Roof insulation may have a significant role in determining the degree of influence on SBS occupants. Responses from occupants give a better understanding of how several occupants react differently to the same “Sick Building Syndrome” (SBS) due to differences in the roof insulation.

### 3. RESULTS AND RESPONSES

To establish that there are SBS issues in the buildings under study apart from the visible signs on them, the end users were asked if they experience SBS conditions.

Do you experience any of the listed conditions as an end user?

**Table 1**

**Table 1 Shows the Respondents' Agreement that SBS Cases Exist in their Building**

Item	Conditions	Frequency of responses							
		Often		Always		Sometimes		Never	
		Flat D	Flat E	Flat D	Flat E	Flat D	Flat E	Flat D	Flat E
1	Lack of air	-	-	-	-	-	1	4	2
2	Supply	-	-	-	-	1	3	3	
3	Very cold	-	-	-	-	-	2	4	1
4	Stuffy	-	-	-	-	1	2	3	
5	Condition	1	-	-	-	3	3	-	-

In Flat D 4 (four) respondents agreed to a large extent the presence of unfavourable SBS causative conditions in their building. While in flat E, the respondents also attested the same SBS causative conditions present in their buildings. The respondents complained of cold conditions, especially during winter and also unpleasant odours from fungi walls, and stuffiness were reported.

According to the table below, respondents were asked if they experienced some of the ailments stated therein.

**Table 2**

**Table 2 Shows End Users' Responses to Health-Impaired Symptoms**

Item	Ailment	Number of Responses									
		Always		Sometimes		Often		Never		Very Frequent	
		Flat D	Flat E	Flat D	Flat E	Flat D	Flat E	Flat D	Flat E	Flat D	Flat E
1	Dry Throat/sour	-	-	1	2	-	-	3	1	-	-
2	Skin Issues	-	-	1	2	-	-	3	1	2	-
3	Aches on the head	-	-	-	1	-	-	4	2	-	1
4	Drowsiness/fainting	-	-	1	1	-	-	3	2	-	-
5	Running nose	-	-	2	-	1	3	2	-	3	-

Occupants of Flat E have a higher response rate to SBS issues compared to occupants of Flat D. End users of Flat E have higher symptoms of SBS like running nose, sour throat, and skin irritation compared to Flat D.

What is your control level over the listed conditions?

**Table 3**

**Table 3 Depicts that the End Users Within the Study Reach Had Different Degrees of Control Over the Conditions in their Buildings**

Item	Room Situation	Number of Responses									
		None		Small		A little		Mostly		Complete	
		D	E	D	E	D	E	D	E	D	E
1	Dry Throat/sour	-	-	-	3	-	-	3	-	1	-
2	Skin Issues	-	-	-	-	-	1	3	2	1	-
3	Aches on the head	-	-	-	-	-	2	4	1	-	-
4	Drowsiness/fainting	-	-	-	-	1	-	3	3	-	-
5	Running nose	-	-	3	3	1	-	-	-	-	-

The data readings show that the roof insulation of the buildings has a part to play in occupants' response to SBS in residential buildings. Ideal insulation gives the occupants better control of living conditions and vice versa. From the results, Flat E delivered a higher level of SBS symptoms on the occupants than Flat D. This supports that the influence of sick building syndrome on occupants is encouraged by inadequate internal temperature regulation or by rapid heat intake and loss. Flat D falls within the acceptable roof insulation type. The suitable insulation type will be discussed later on.

Furthermore, occupants of Flat D seem to have fewer SBS symptoms in comparison to occupants of Flat E even when indoor activities which could promote SBS formation like smoking occur in Flat D as in Flat E.

From a deeper observation, data analysed depicts that the main causes of sick building syndrome ailment on occupants are factors like:

- Stuffy air

- Inadequate air supply
- Dim light
- Cold spaces
- Unpleasant odour in the living buildings

All the factors mentioned above especially the cold spaces mostly experienced in winter are directly connected to roof insulation and the type of thermal floor mass used. It is also evident that, at least within the parameters of this work, variations in roof insulation can be linked to variations in the SBS test results, given that the two apartments have identical designs, were constructed at the same time using the same building materials, and have students living in them. The table indicates that Flat E had a more severe SBS effect on occupants than Flat D.

### The Ideal Roofing System

Ideal roof insulation reduces the SBS effect on occupants to a great extent. Symptoms like headache, running nose, skin dryness, sore throat, and skin dryness can be reduced if a roof building is ideally insulated. Ideal roof insulation allows for adequate temperature control in the building [Tulchinsky et al. \(2023\)](#). Rapid heat loss or gain through insulated roofs can create an unnecessary need for a high mechanical cooling or heating system which increases costs. I conducted a comparison between bulk insulation and concertina foil batts in an attempt to determine the best roofing system for residential structures in Cyprus as well as methods for insulating roofs that already existed. By comparing the two, this study determined which type would be more suited for hot and cold climates, and this will direct my suggestions. It was also discovered that, with proper design, both insulators could be utilized in hot and cold areas [Mølhave \(1989\)](#). The table below shows ideal roof designs for Cyprus roofing.

**Table 4**

<b>Table 4 Comparison Between Concertina Foil and Bulk Insulation Roof Result</b>		
	<b>Concertina Foil Batt</b>	<b>Bulk Insulation</b>
Dead load	10.5kg (m2)	19.45kg (m2)
Durability	88.1%	56.7%
Cyprus Requirement	Ideal	Good
Safety	Ideal	Good

The illustrations and the principles are as follows:

Sarking or foil batts installed under the roof increased the roof's ability to resist radiant heat. This could be used in regions with extreme heat. During installation, great care should be taken to ensure a minimum of 25mm space (gap) for reflective surfaces. RFL sarking should be placed directly beneath the roofing components of the battens and rafter making sure the glossy side is facing downwards. The joist element of the ceiling is more suitable for insulation placement.

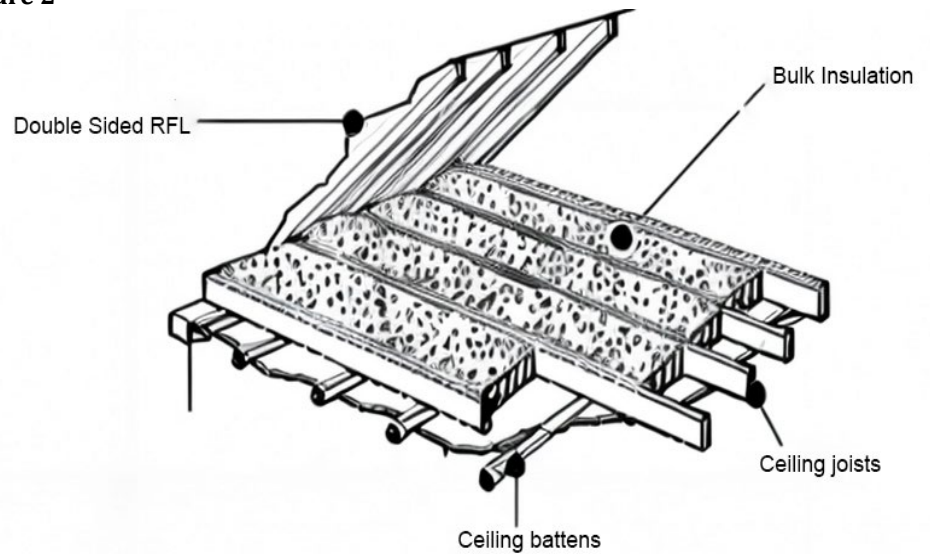

**Figure 2****Figure 2** Bulk Insulation Installation

For bulk insulation installations to be successful, polystyrene boards, bulk batts, and loss fillers are needed. In very cold climatic regions of about 10 months of the cold season, double layers of this type of insulation (Bulk insulation) to increase the roof's thermal floor characteristics are recommended. This is best done by placing one layer on the joist and the other on top.

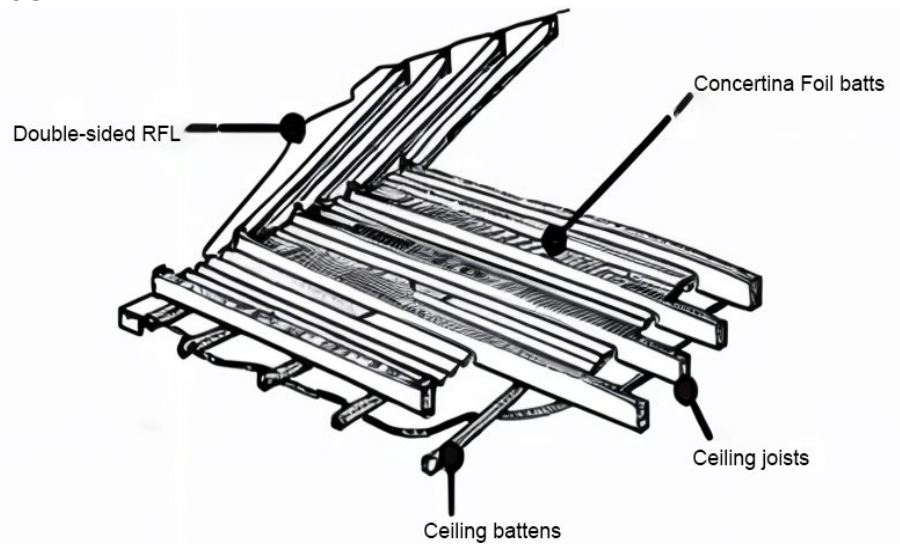
**Figure 3****Figure 3** Reflective Insulation Installation

When the ceiling joist is covered up by insulation materials, it's hard to identify a safe part of the roof to walk on. Therefore, when the roof is accessed, care must be taken to reinstall the installation material according to the set-out standard [Obi \(2016\)](#).

Figure 4

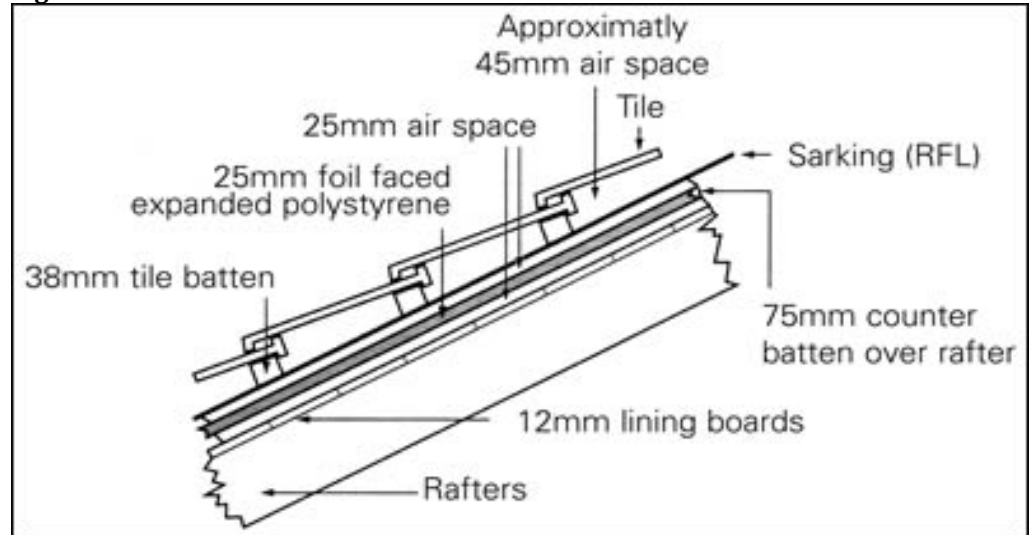

Figure 4 Roof Section

In general, it is important to follow all necessary guidelines while installing roofing components; it is best to place the insulation material between the joists [Shuttleworth \(2008\)](#). The effects of insulation will be significantly reduced if these roof insulation guidelines are not followed.

#### 4. CONCLUSION

Given the differences in construction cultures, concertina foil bats would be more suitable in Cyprus than bulk insulation because roof designs are valued less there than in many other countries. In actuality, there are no identifiable roof designs on more than 75% of residential buildings in North Cyprus [Obi \(2016\)](#). Additionally, keeping the heat inside the internal areas will be substantially aided by the ceiling's usage of timber roof finishes.

Roof insulation in Cyprus must be carefully designed to meet the standards and requirements of the local climate. For example, the roof insulation designs should be able to retain heat during winter and relinquish excess heat during summertime, given the country's harsh winters and hot summers [Morantes et al. \(2023\)](#).

Cyprus faces roofing difficulties due to the use of deck roofs; potential solutions include:

- Design and install wooden materials as internal ceiling materials to keep heat in.
- Construct a roof design on top of the deck roof.

Insulated roofs would cut the cost of heating and cooling for any building [Joshi \(2008\)](#). In other parts of the world, particularly in the Mediterranean climatic axis, roof insulation is a crucial architectural consideration. Great attention is put on insulation during cold months, especially the winter. The purpose of insulation designs and mechanics is to shield living areas from cold, especially when snow accumulates on the roof [Mosher & McGee \(2013\)](#). A typical residential building in a northern climate would benefit greatly from both a bulk insulated roof and an insulated roof made of concertina foil bats.

## CONFLICT OF INTERESTS

None.

## ACKNOWLEDGMENTS

None.

## REFERENCES

- Apte, M., Fisk, W. J., & Daisey J. (2000). Associations Between Indoor CO<sub>2</sub> Concentrations and Sick Building Syndrome Symptoms in U.S. Office Buildings: An Analysis of the 1994-1996 BASE Study Data. *International Journal of Indoor Environment and Health*, 10(4), 246-257. <https://doi.org/10.1034/j.1600-0668.2000.010004246.x>
- Arikrishnan, S., Roberts, A. C., Lau, W. S., Wan, M., P., & Ng, B. F. (2023). Experimental Study on the Impact of Indoor Air Quality on Creativity by Serious Brick Play Method. <https://doi.org/10.1038/s41598-023-42355-z>
- Joshi, S. M. (2008). The Sick Building Syndrome. *Indian Journal of Occupational and Environmental Medicine*, 12(2), 61-64. <https://doi.org/10.4103/0019-5278.43262>
- London Hazards Centre. (1990). *Sick Building Syndrome: Causes, Effects and Control*.
- Morantes, G., Jones, B., Sherman, M., & Molina, C. (2023). A Preliminary Assessment of the Health Impacts of Indoor Air Contaminants Determined using the DALY Metric. *International Journal of Ventilation*, 22(4), 307-316. <https://doi.org/10.1080/14733315.2023.2198800>
- Mosher, M., & McGee, C. (2013). *Insulation Installation*. Archicentre Australia.
- Mølhave, L. (1989). The Sick Buildings and Other Buildings with Indoor Climate Problems. *Environmental International*, 15(1-6), 65-74. [https://doi.org/10.1016/0160-4120\(89\)90011-1](https://doi.org/10.1016/0160-4120(89)90011-1)
- Mølhave, L. (1991). Volatile Organic Compounds, Indoor Air Quality and Health. *International Journal of Indoor Environment and Health* 1(4), 357-376. <https://doi.org/10.1111/j.1600-0668.1991.00001.x>
- Norbäck, D. (2009). An Update on Sick Building Syndrome. *Current Opinion in Allergy and Clinical Immunology* 9(1), 55-59. <https://doi.org/10.1097/ACI.0b013e32831f8f08>
- Obi, I. C. (2016). Strategic Management in Building Designs for Sick Building Syndrome Control: The Effect of Ideal Building Orientation. *ARP International Journal of Social Science*, 1(1), 13-23. <https://doi.org/10.5281/zenodo.44746>
- Seppänen, O., & Fisk, W. J. (2002). Association of Ventilation System Type with SBS Symptoms in Office Workers. *International Journal of Indoor Environment and Health*, 12(2), 98-112. <https://doi.org/10.1034/j.1600-0668.2002.01111.x>
- Shuttleworth, M. (2008). *Case Study Research Design*.
- Skov, P., Valbjørn, O., & Pedersen, B. V. (1989). Influence of Personal Characteristics, Job-Related Factors and Psychosocial Factors on the Sick Building Syndrome. Danish Indoor Climate Study Group *Scandinavian Journal of Work, Environment and Health*, 15(4), 286-295 <https://doi.org/10.5271/sjweh.1851>



- Tulchinsky, T. H., Varavikova, E. A., & Cohen, M. J. (2023). *The New Public Health*. Academic Press. <https://doi.org/10.1016/C2019-0-04675-4>
- Wargoeki, P., Wyon, D. P., Sundell, J., Clausen, G., & Fanger, P. O. (2000). The Effects of Outdoor Air Supply Rate in an Office on Perceived Air Quality, Sick Building Syndrome (SBS) Symptoms and Productivity. *International Journal of Indoor Environment and Health*, 10(4), 200-236. <https://doi.org/10.1034/j.1600-0668.2000.010004222.x>