



EFFICIENCY IMPROVEMENT OF ELECTRIC VEHICLE BY USING ACTIVE FILTERS

Miss. Vrishali Sanjay Bhutkar ^{*1}, Dr. Mrs. Haripriya H. Kulkarni ²

^{*1} Electrical Engineering, PES's MCOE, Pune, Savitribai Phule Pune University, Pune, Maharashtra, India

² Associate Professor, PES's MCOE, Pune, Savitribai Phule Pune University, Pune, Maharashtra, India



Abstract:

In electric vehicle is new emerging trend, because cost of fuel is increasing and air pollution is also increasing. Electric vehicle is control the air pollution. Electric vehicle also gives less cost per kilometer. Electric vehicles can run up to 450 km in a single battery charge to achieve this distance normal fuel consumes very large amount of fuel giving rise to costly journey as well as rise in air pollution but in case of electric vehicles does not pollute air and have high fuel efficiency because of this it is very beneficial for the society.

In electric vehicles battery pack is uses to give power to electric motors. Battery is dc supply. Inverter is converted DC to impure AC supply having large harmonics, these harmonics reduces the efficiency of electric motor that as electric vehicle. This work shows some MATLAB simulation of inverter has done 21 levels.

This simulation gives approximate output. As a result, THD reduce.

Keywords: AC Motor Drives; Cascaded H-Bridges (CHBs); Electric Vehicles (EVs); Multilevel Converter.

Cite This Article: Miss. Vrishali Sanjay Bhutkar, and Dr. Mrs. Haripriya H. Kulkarni. (2019). "EFFICIENCY IMPROVEMENT OF ELECTRIC VEHICLE BY USING ACTIVE FILTERS." *International Journal of Engineering Technologies and Management Research*, 6(6), 18-25. DOI: <https://doi.org/10.29121/ijetmr.v6.i6.2019.390>.

1. Introduction

In modern world electric vehicle is new emerging trend, because cost of fuel is increasing and air pollution is also increasing, electric vehicle is a new way to control the air pollution. Electric vehicle also gives less cost per kilometer. Electric vehicles can run up to 450 km in a single charge to achieve this distance normal fuel consumes very large amount of fuel giving rise to costly journey as well as rise in air pollution.

In electric vehicles battery pack are used to give power to electric motors, battery gives DC supply this is to be converted to AC using inverter. Inverter gives very impure AC supply having large harmonics, these harmonics reduces the efficiency of electric motor that as electric vehicle.

Cascaded H-bridge (CHB) multilevel drives have become very popular because they generate voltage waveforms with negligible distortion when compared with conventional machine drives based on two- or three- level inverters [1]. This characteristic looks attractive for applications in electric vehicles(EV) because it improves the efficiency of the traction motor (fewer harmonic currents) and reduces size (less isolation required) However, the great barrier for practical application of CHB in EVs is the large number of independent voltage supplies required for its operation. An important improvement over the CHB is the “asymmetrical CHB” (ACHB) because it can generate the same number of levels with fewer power supplies [4].ACHBs use H-bridges fed with dc voltages of different magnitude. Where that which uses the larger dc source is called the MAIN Bridge. When the dc voltages are scaled in power of three, the MAIN Bridge carries more than 80% of the total power and works at fundamental frequency.[6]. These characteristics remarkable reduce the switching losses, improving the efficiency of the system. The rest of the H-bridges called Aux-bridges (auxiliary bridges) allows the generation of several voltage levels, reducing the total harmonic distortion (THD) and common-mode voltages. However ACHBs still need more that one isolated power source, and a result, the use of these technologies in EVs becomes difficult to implement [8].

The total harmonic distortion (THD) is a measurement of the harmonic distortion present in a signal and is defined as the ratio of the sum of the powers of all harmonic components to the power of the fundamental frequency.

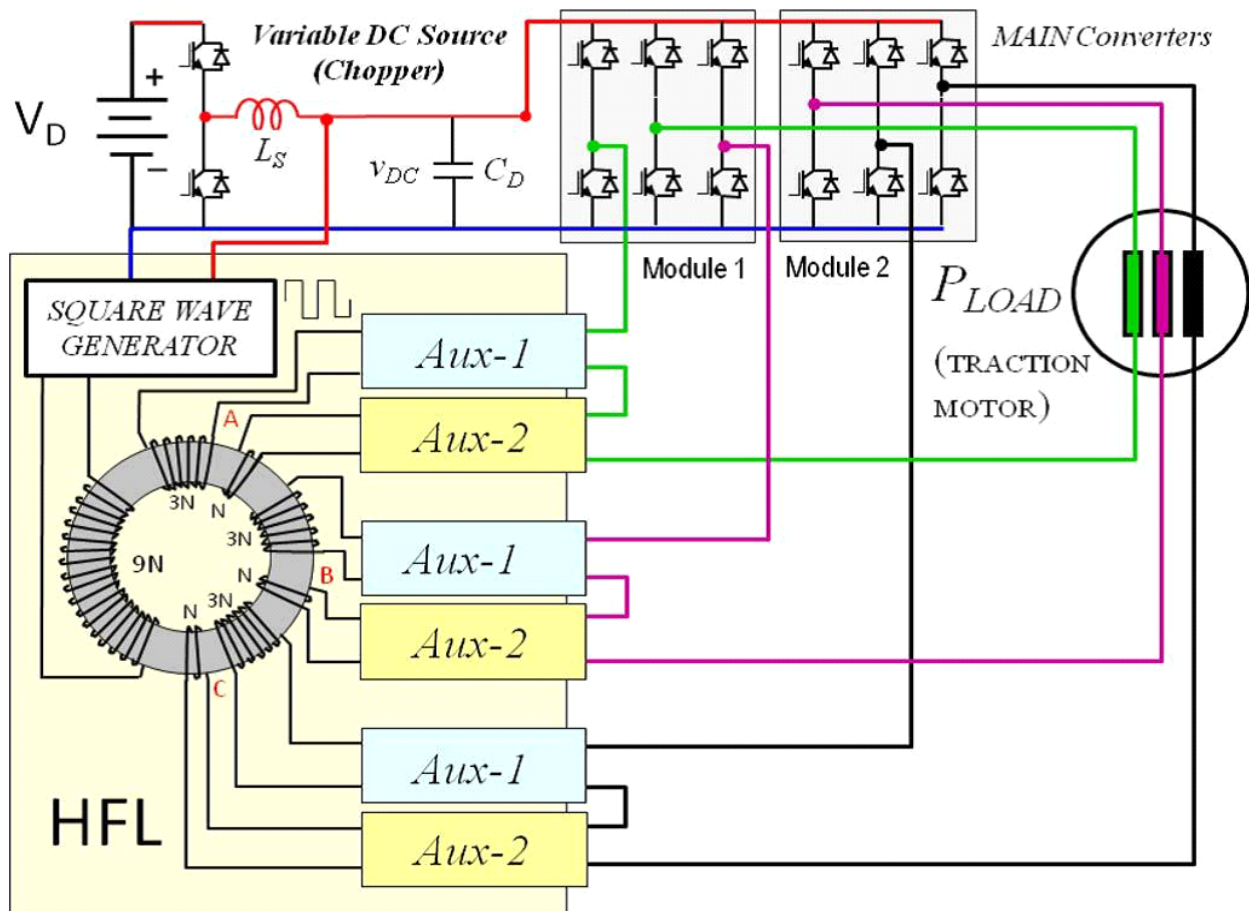

Figure 1: Circuit Diagram of whole system [1]

2. Operation characteristics of asymmetrical cascaded H-Bridge Inverter

Figure 1. shows a complete three phase motor drive for an EV. The CHB is the “asymmetrical CHB” (ACHB) because it can generate the same number of levels with fewer power supplies. ACHBs use H-bridges fed with dc voltages of different magnitudes, where that which uses the larger dc source is called as main bridge. When the dc voltages are scaled in powers of three, the MAIN bridge carries more than 80% of the total power and works at fundamental frequency. This characteristic remarkably reduces the switching losses, improving the efficiency of the system. The rest of the H-bridges called Aux-bridges (auxiliary bridges) allows the generation of several voltage levels, reducing the total harmonic distortion (THD) and common- mode voltages. However, ACHB’s still need more than one isolated power source, and as a result, the use of these technologies in EV’s becomes difficult to implement.

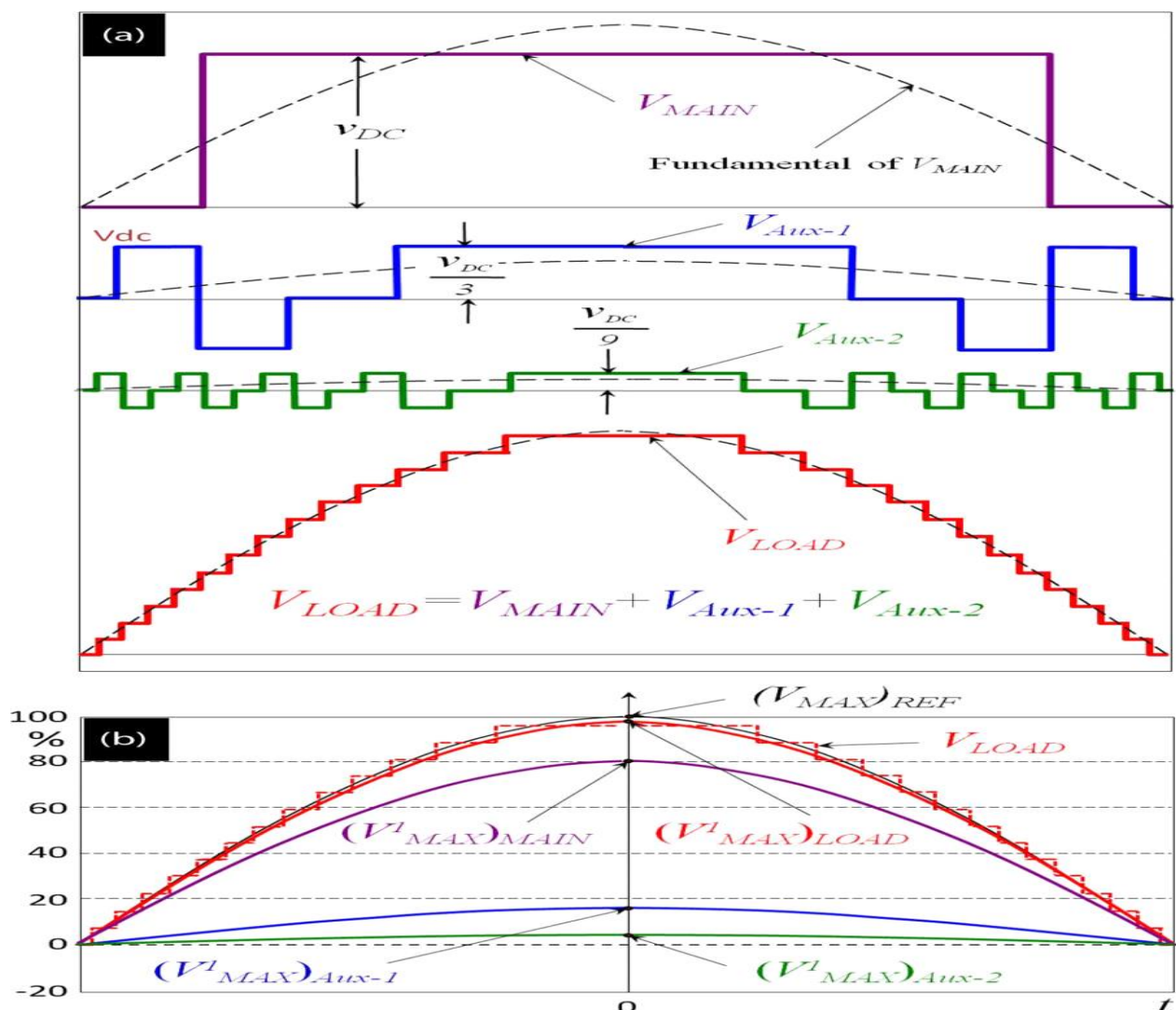

Figure 2: (a) voltage waveforms of each H-bridge using NLC modulation, with their fundamentals in dotted lines. (b) Fundamental of voltages at each bridge at load and reference voltage.

The main objective of this work is to find an HFL that is as small as possible for EV applications, and this research has found that, with proper modulation adjusted, the power rating of the Toroidal transformer (hence, the HFL) can be minimized. The proposed control strategy reduces the size of the HFL from 20% to less than 2% of the power transferred to the machine. To achieve this, the reference voltage of the ACHB converter is adjusted to operate with a reduced number of levels. This paper demonstrates that, if a 27-level ACHB converter works with only 21 levels, some H-bridges will not transfer any power to the load, and then, they behave like series active filters. The amplitude of the load voltage is controlled with a variable dc source (Chopper) that manages all the isolated supplies generated by the HFL.

The power sources of each H-Bridge (V_{MAIN} , V_{Aux-1} , and V_{Aux-2}) are replaced by only one variable dc source, which transfers to the smallest H-bridges (Aux-1 and Aux-2) through the HFL. This HFL connects the three H-bridges through a small Toroidal transformer with windings scaled in powers of 3, as shown in fig.1. This transformer is required to isolate the power supplies of MAIN, Aux-1, and Aux-2 bridges. The traction motor can be either an induction motor or a permanent- motor- machine (brushless dc or brushless synchronous) Aux-2 the converter uses the modulation called nearest level control (NLC), which is one of the simplest modulation strategies for this kind of converter. The NLC consists of taking the level of voltage closest to the reference. The NLC permits to operate the H-bridges at very low switching frequency.

Figure 2. shows the half cycle of the voltage waveform of the ACHB using NLC modulation. It displays the voltage waveforms of each H-bridge (V_{MAIN} , V_{Aux-1} , V_{Aux-2}) and the resultant voltage waveform (V_{LOAD}) that feeds the machine. As shown in Fig.2 (a), the MAIN bridges switch at fundamental frequency, reducing power loss. The sinusoidal waveform (V_{MAX})_{REF} shown in fig. 2 (b) is the amplitude of the reference voltage that generates the NLC modulation [1].

3. Transformer Design

As the HFL works at high frequency 10 kHz. Its size and weight becomes very small. For example, in a 100kw machine drive for an EV. A 1.9kw HFL is required. Working at a frequency of 10 kHz and with a flux density of 0.2T, a core transformer of 4cm² (2 X 2 cm) with an internal diameter of 3cm and an external diameter of 7 cm is appropriate. The number of turns depends on the battery voltage and should be in the rate 9N:3N: N for MAIN, Aux-1, and Aux-2, respectively. [1]

4. Variable DC Source Design

As the PWM pattern for all H-bridges must remain constant, this enormously simplifies the task of the controller. For this reason, a variable dc source to control VDC has been implemented using a bidirectional chopper with one insulated gate bipolar transistor (IGBT) module. the most relevant part of this chopper, is the inductor LDC, which needs to be small and light, as the a chopper will be smaller and its switching frequency will be smaller, and weight will be less than 15kg.

5. H-Bridge Inverter

The term H-bridge is derived from the typical graphical representation of such a circuit. An H-bridge is built with four switches (solid-state or mechanical). When the switches S1 and S4

(according to Fig.3) are closed (and S2 and S3 are opens) a positive voltage will be applied across the motor. By opening S1 and S4 switches and closing S2 and S3 switches. This voltage is reversed, allowing reverse operation of the motor. Using the nomenclature above, the switches S1 and S2 should never be closed at the same time, as this would cause a short circuit on the input voltage source. The same applies to the switches S3 and S4. This condition is known as shoot-through.

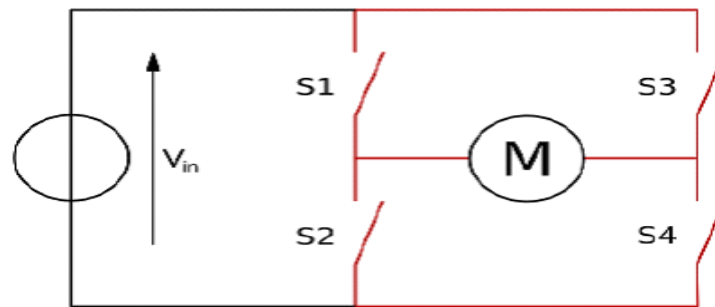

Figure 3: H-bridge circuit

6. Result and Analysis

By simulation this circuit to successfully to get approximate output of each block of this circuit and this result are as shown in fig.3 by implementing simulation of DC link we get expected output of constant voltage. Main converter gives frequency of 60 Hz. High frequency link creates 10 kHz outputs which is fed to auxiliary circuit. Outputs of all converters are super imposed to get final power supply.

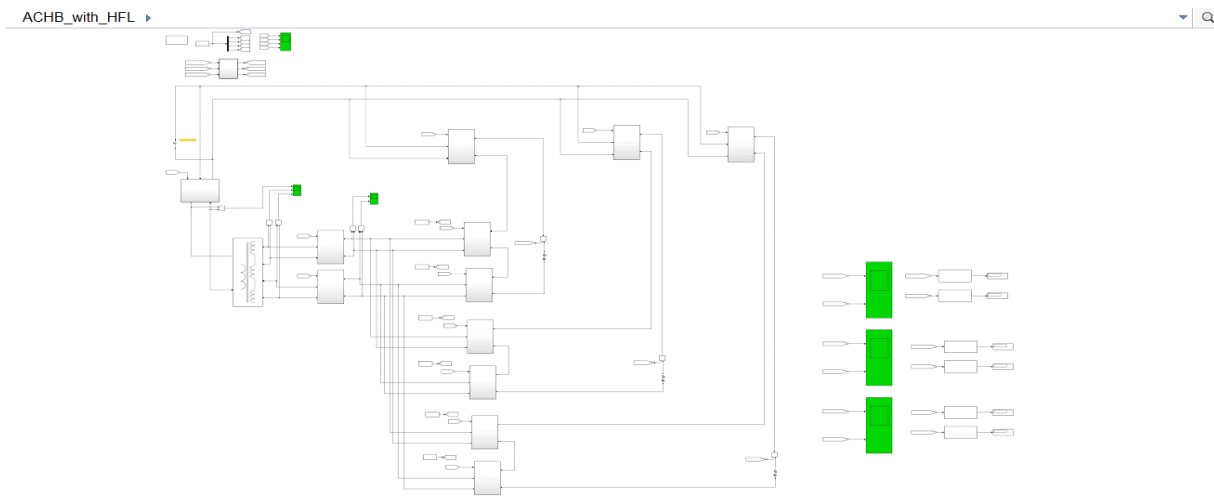

Figure 4: MATLAB Simulation diagram

Figure 4. shows the main components of the 21-level multilevel inverter. This has been built two different topologies. A) Using four individual voltage source of each module [4]. B) Using one single voltage source for all module and voltage escalation through output transformer [4]. This arrangement has been successfully implemented.

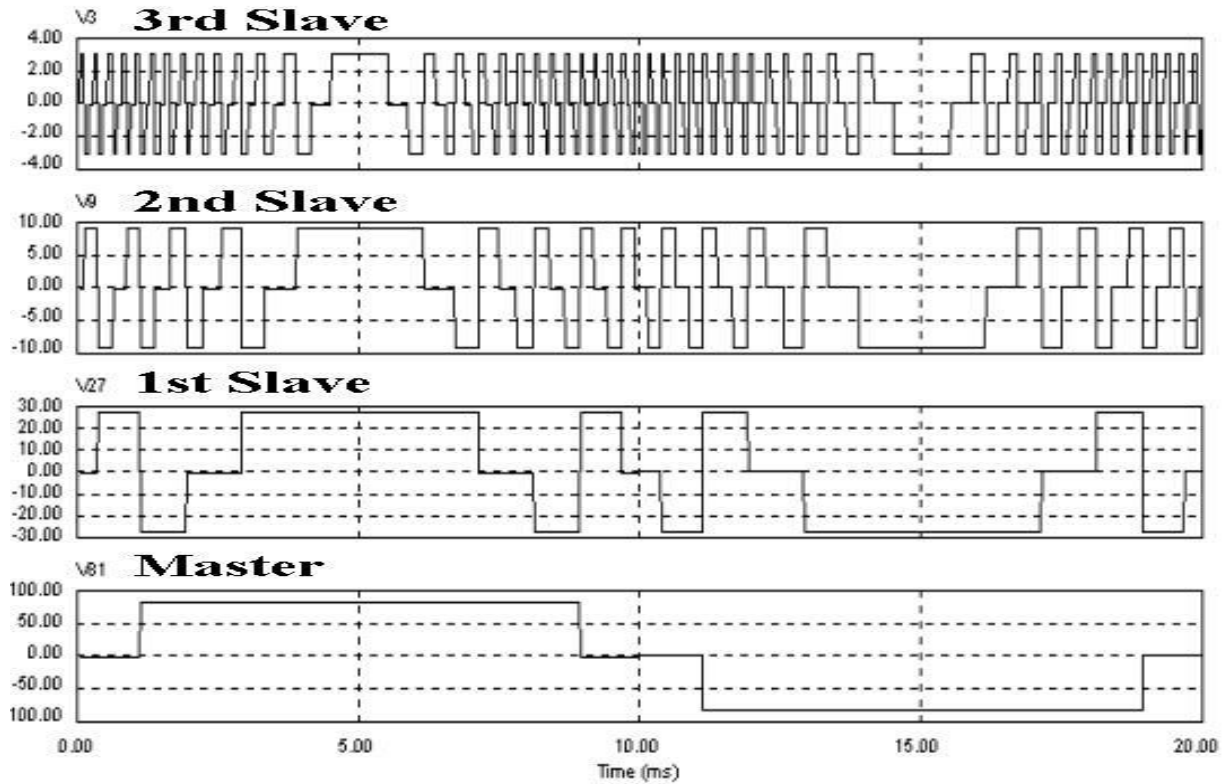

Figure 5: frequency modulator for each converter

One important characteristics of multilevel inverter using voltage escalation is that electric power distribution and switching frequency present advantages for the implementation of these topologies. Figure 5.shows frequency distribution of each one of the four bridge used for implementation of 21-level multilevel inverters [4].

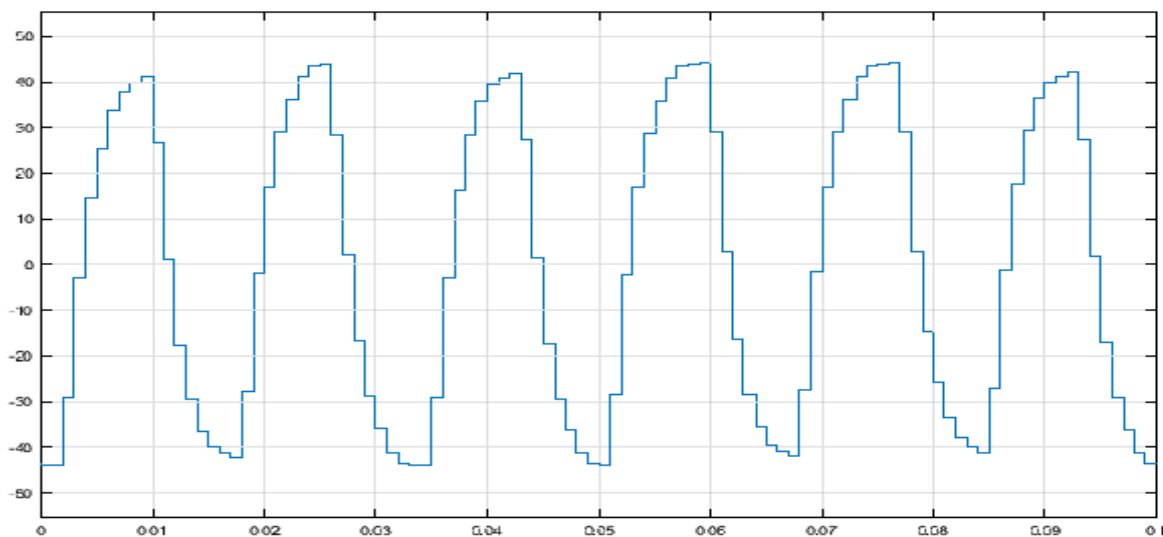

Figure 6: Simulation Result

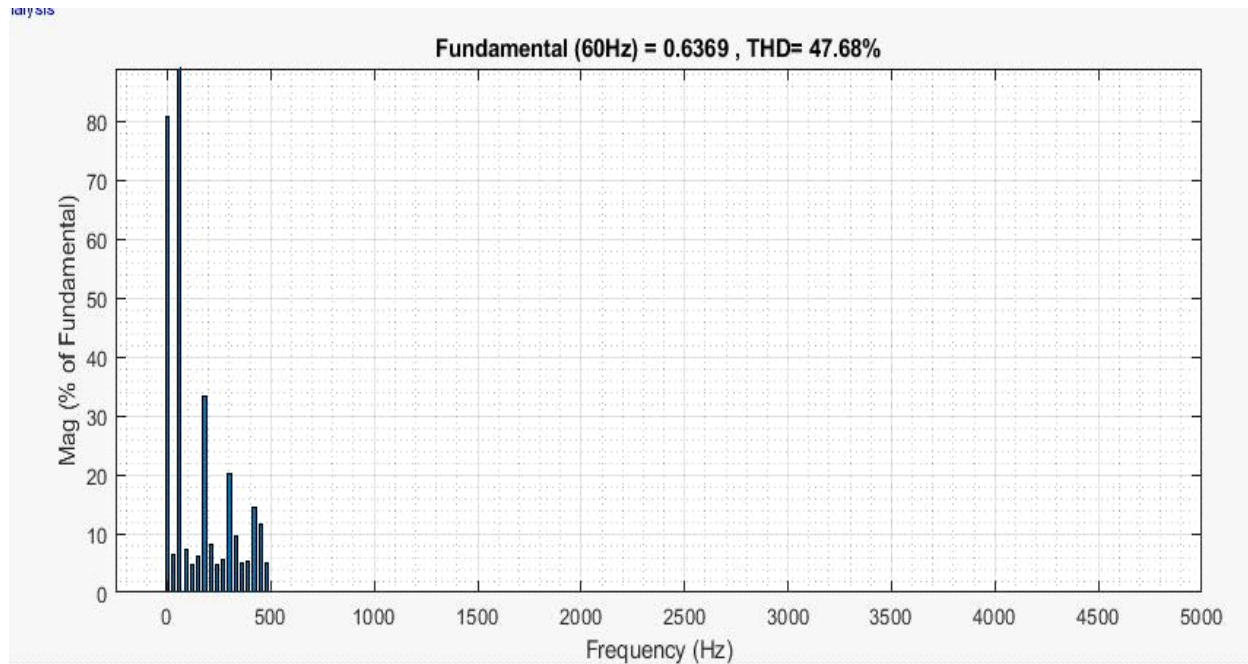

Figure 7: Total Harmonic Distortion

Multi-level inverter can operate not only with PWM technique but also with amplitude modulation (AM), improving significantly the quality of the output voltage. Waveform, with the use of amplitude modulation, low frequency, and voltage harmonics are perfectly eliminated. Generating almost perfect sinusoidal waveform, with a total harmonics distortion lower than 5%. Another important characteristic is that each inverter operated at lower switching frequency reducing the semiconductor stresses, and therefore reducing switching losses. [4]

7. Future Scope

Until now we have designed and analyze in inverter and filter circuit. In future, we can design controller circuit to control voltage, control frequency of inverter, and filter. This circuit can be farther developed for electric sports car. By using specific electrical and mechanical designed topologies we can reduce size, cost, and weight.

Applications

Electric traction system.

Electric car (electric vehicles)

8. Conclusion

In this paper, H-bridge inverter has been studied and a implemented simulation in MATLAB software. It has feasibility of using ACHB multilevel inverter in electric vehicle. With an appropriate design and adjustment of the ACHB, only less amount of power is transferred through the small H-bridges of the ACHB (AUX bridges). The topology and the switching strategy make some of the Aux- bridges work as series active filter. Therefore, the circuit works efficiently to reduce harmonics of final output voltage and increase power quality of supply and improvement of efficiency of electric vehicle.

The MAIN bridges work at fundamental frequency (only two switching actions per cycle) and because they manage more than 98% of the power. The switching losses of the overall converter become very small. On the other hand, as the Aux-1 bridges transfer no power, they behave as series active power filters. The HFL is bidirectional, and then, the ACHB can work at full regenerative braking. The work is focused on electric traction drives, but the idea can be extended to other applications and in the range of megawatts.

References

- [1] 23- Level Inverter for Electric Vehicles using a single battery pack and series active filters Javier Pereda, Student member, IEEE, and Juan Dixon, Senior Member, IEEE transactions on vehicular technology, Vol.61. No.3 March 2012.
- [2] L. G. Franquelo, J. Rodriguez, J. I. Leon, S. Kouro, R. Portillo, and M. A. M. Prats, "The age of multilevel converters arrives," *IEEE Ind Electron. Mag.*, vol. 2, no. 2, pp. 28–39, Jun. 2008.
- [3] W. Jun and K. M. Smedley, "Synthesis of multilevel converters based on single- and/or three-phase converter building blocks," *IEEE Trans. Power Electron.*, vol. 23, no. 3, pp. 1247–1256, May 2008.
- [4] J. Dixon and L. Moran, "High-level multistep inverter optimization using a minimum number of power transistors," *IEEE Trans. Power Electron.*, vol. 21, no. 2, pp. 330–337, Mar. 2006.
- [5] C. Rech and J. Pinheiro, "Hybrid multilevel converters: Unified analysis and design considerations," *IEEE Trans. Ind. Electron.*, vol. 54, no. 2, pp. 1092–1104, Apr. 2007.
- [6] J. Dixon and L. Moran, "Multilevel inverter, based on multi-stage connection of three-level converters scaled in power of three," in *Proc. 28th IEEE IECON*, 2002, vol. 2, pp. 886–891.
- [7] M. Manjrekar, P. Steimer, and T. Lipo, "Hybrid multilevel power conversion system: A competitive solution for high-power applications," *IEEE Trans. Ind. Appl.*, vol. 36, no. 3, pp. 834–841, May/Jun. 2000.
- [8] J. Dixon, A. Breton, F. Rios, J. Rodriguez, J. Pontt, and M. Perez, "High-power machine drive, using nonredundant 27-level inverters and active front end rectifiers," *IEEE Trans. Power Electron.*, vol. 22, no. 6, pp. 2527–2533, Nov. 2007.
- [9] L. Maharjan, S. Inoue, H. Akagi, and J. Asakura, "A transformer less battery energy storage system based on a multilevel cascade PWM converter," in *Proc. IEEE PESC*, 2008, pp. 4798–4804.
- [10] M. Rotella, G. Penailillo, J. Pereda, and J. Dixon, "PWM method to eliminate power sources in a nonredundant 27-level inverter for machine drive applications," *IEEE Trans. Ind. Electron.*, vol. 56, no. 1, pp. 194–201, Jan. 2009.
- [11] D. Zhong, B. Ozpineci, L. M. Tolbert, and J. N. Chiasson, "DC-AC cascaded H-bridge multilevel boost inverter with no inductors for electric/ hybrid electric vehicle applications," *IEEE Trans. Ind. Appl.*, vol. 45, no. 3, pp. 963–970, May/Jun. 2009.

*Corresponding author.

E-mail address: vrishabhutkar@ gmail.com